



# DELTA-XERO

THE FUTURE IS SYSTEM RELIABILITY

## DX1012-T-PT

The modern, eco-friendly solution to fluid conditioning for Diesel

- Particle filtration down to **0.1 µm**
- Designed for diesel and kerosene
- Smart & effective maintenance system
- Operation and maintenance cost reduction
- Extend equipment lifetime
- Eco-friendly
- Easy to service
- Reduced emissions
- **100% Recycled** media
- 



Maintaining healthy fluid by removing:

- Abrasive material to down 0.1 µm
- Bacteria
- Fungus
- Ashphaltenes
- Wax deposits
- Water bound free and emulsified

### DX1012-T-PT

Drive Input	Electric
Connection Ports	1" BSP In & 3/4" BSP Out
Flow Indicator	Visual
Suggested System Volume	Fluid dependant
Flow Rate	Starting from 24 lpm - Varies per application
Particulate Removal	From 0.1 µm
Weight	85Kg
Dimensions	H 1158 mm x D 300 mm x L 1374 mm
Material	SS316
DXPT Cartridge QTY	12

© 2022 Delta-Xero All Rights Reserved. All information contained in this publication is indicative only and may be subject to change without prior notice.



Delta-Xero Distribution Ltd  
 Unit 5, Pennant Park, Standard Way,  
 Fareham, Hampshire,  
 PO16 8XU  
 t: +44 2392 874 755  
 e: sales@delta-xero.com



# DELTA-XERO

THE FUTURE IS SYSTEM RELIABILITY

## General Arrangement

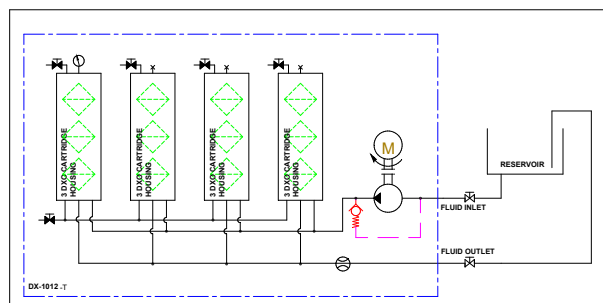
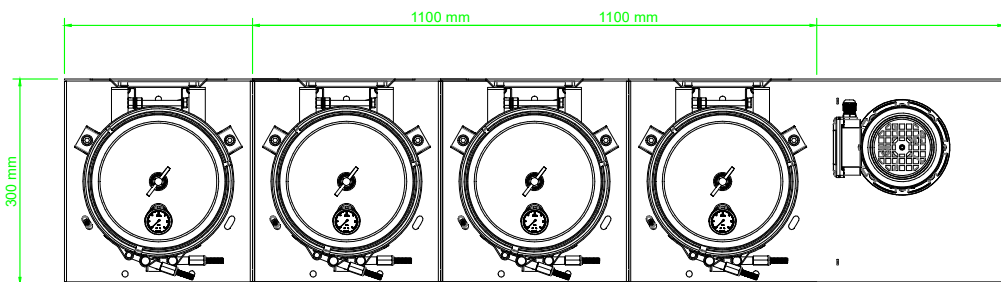
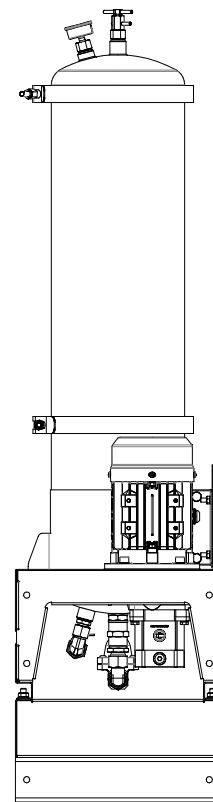
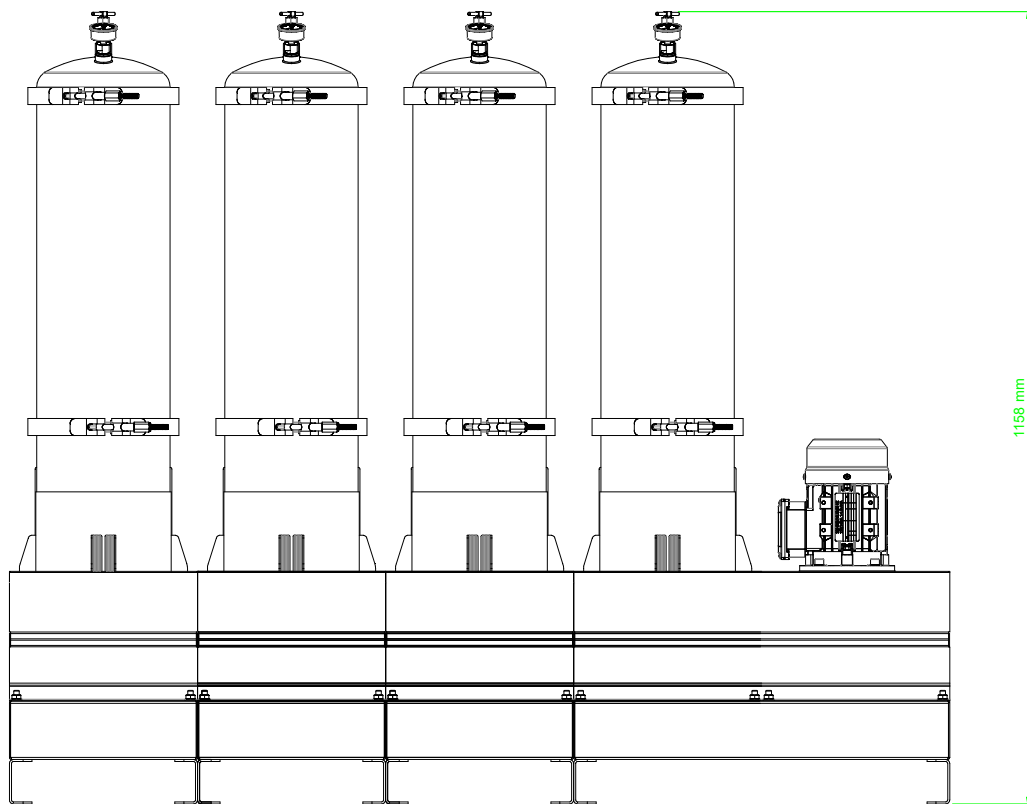

© 2022 Delta-Xero All Rights Reserved. All information contained in this publication is indicative only and may be subject to change without prior notice.



Delta-Xero Distribution Ltd  
 Unit 5, Pennant Park, Standard Way,  
 Fareham, Hampshire,  
 PO16 8XU  
 t: +44 2392 874 755  
 e: sales@delta-xero.com